

Flat Pattern view
SCALE: 1:10

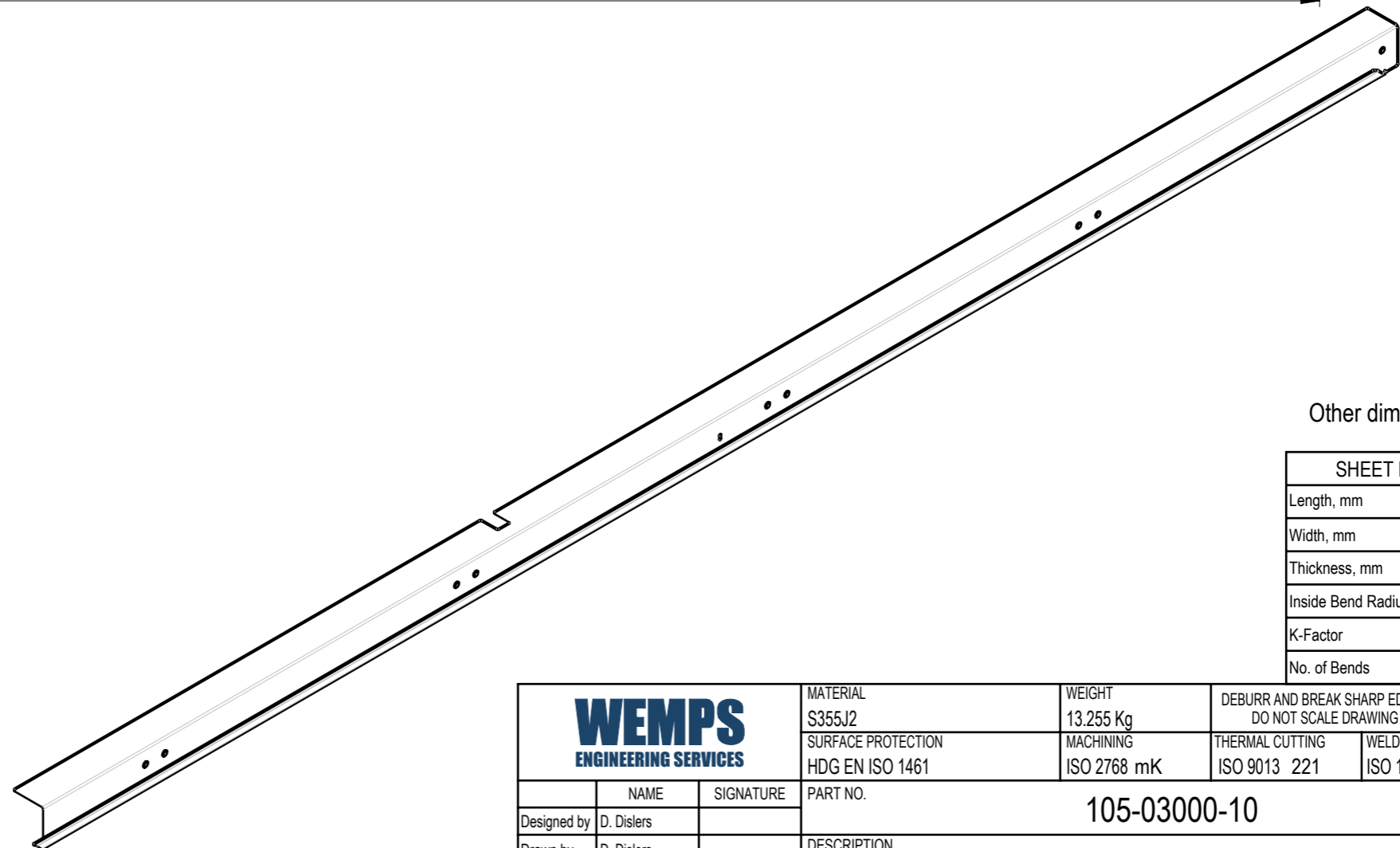
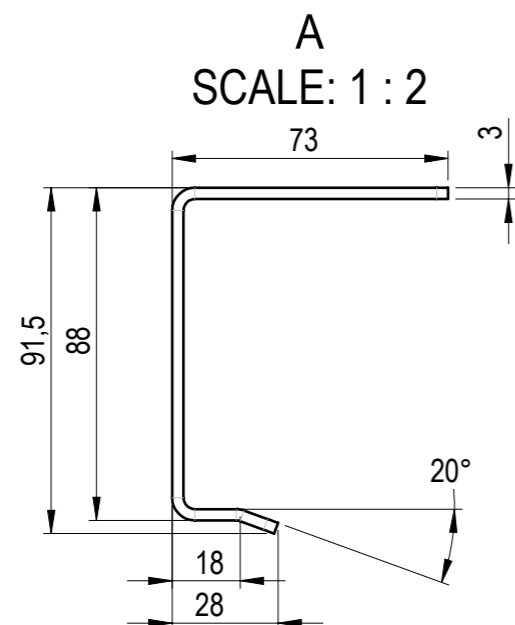
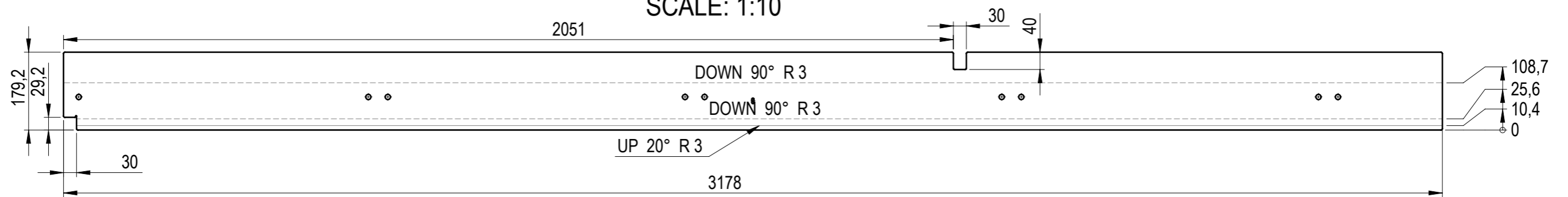

Other dimensions from .DXF file.

| SHEET METAL INFORMATION | |
|-------------------------|-------|
| Length, mm | 3178 |
| Width, mm | 179.2 |
| Thickness, mm | 3 |
| Inside Bend Radius, mm | 3 |
| K-Factor | 0.5 |
| No. of Bends | 3 |

| | | | | | | |
|----------------|--------------------|-------------|------------------------------|--------------|----------|------------|
| | MATERIAL | WEIGHT | DEBURR AND BREAK SHARP EDGES | | REVISION | DATE |
| | S355J2 | 13.255 Kg | DO NOT SCALE DRAWING | | | 23.05.2025 |
| | SURFACE PROTECTION | MACHINING | THERMAL CUTTING | WELDING | SCALE | FORMAT |
| | HDG EN ISO 1461 | ISO 2768 mK | ISO 9013 221 | ISO 13920 BF | 1:10 | A3 |
| | NAME | SIGNATURE | PART NO. | | | |
| Designed by | D. Dislers | | 105-03000-10 | | | |
| Drawn by | D. Dislers | | DESCRIPTION | | | |
| Technical ref. | | | Panel bracket 1-1 | | | SHEET 1/1 |